

REVISION HISTORY		DATE	DRW	CHK	APR
REV	DESCRIPTION				

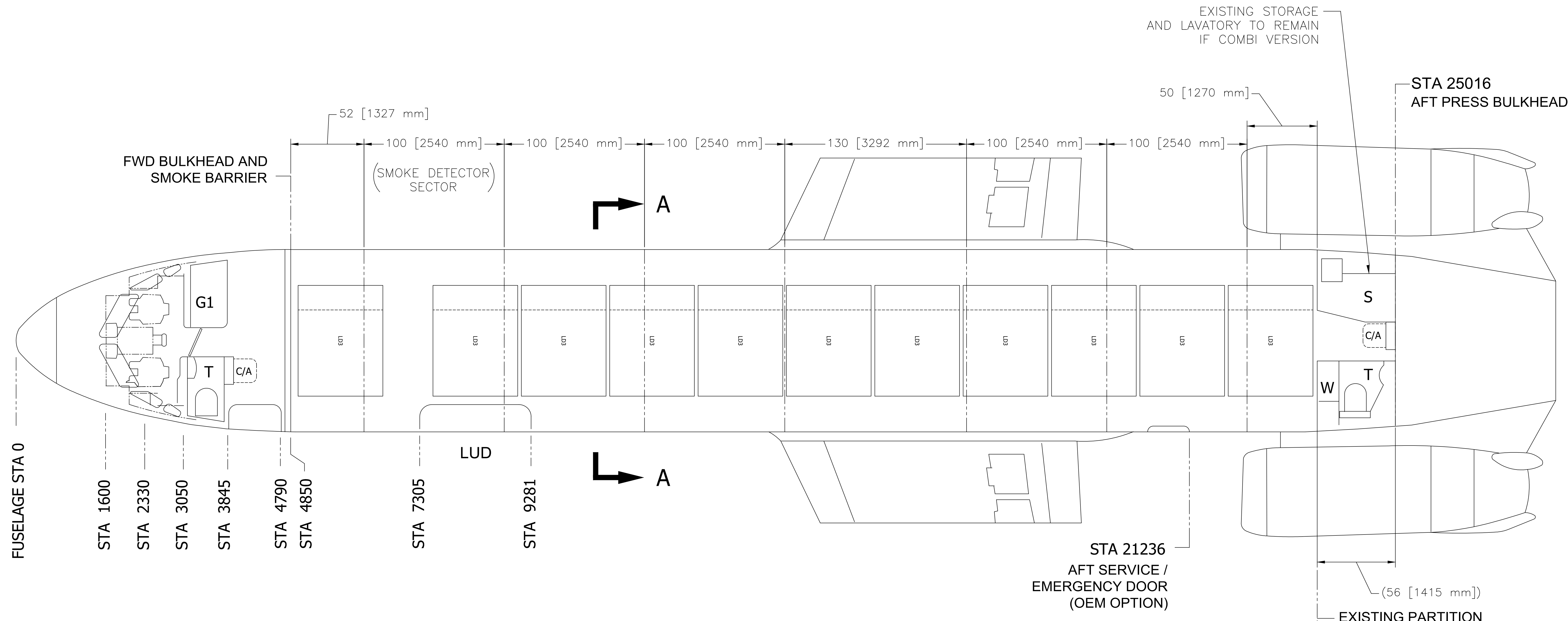

VIEW SHOWING LD3 CONTAINER ARRANGEMENT

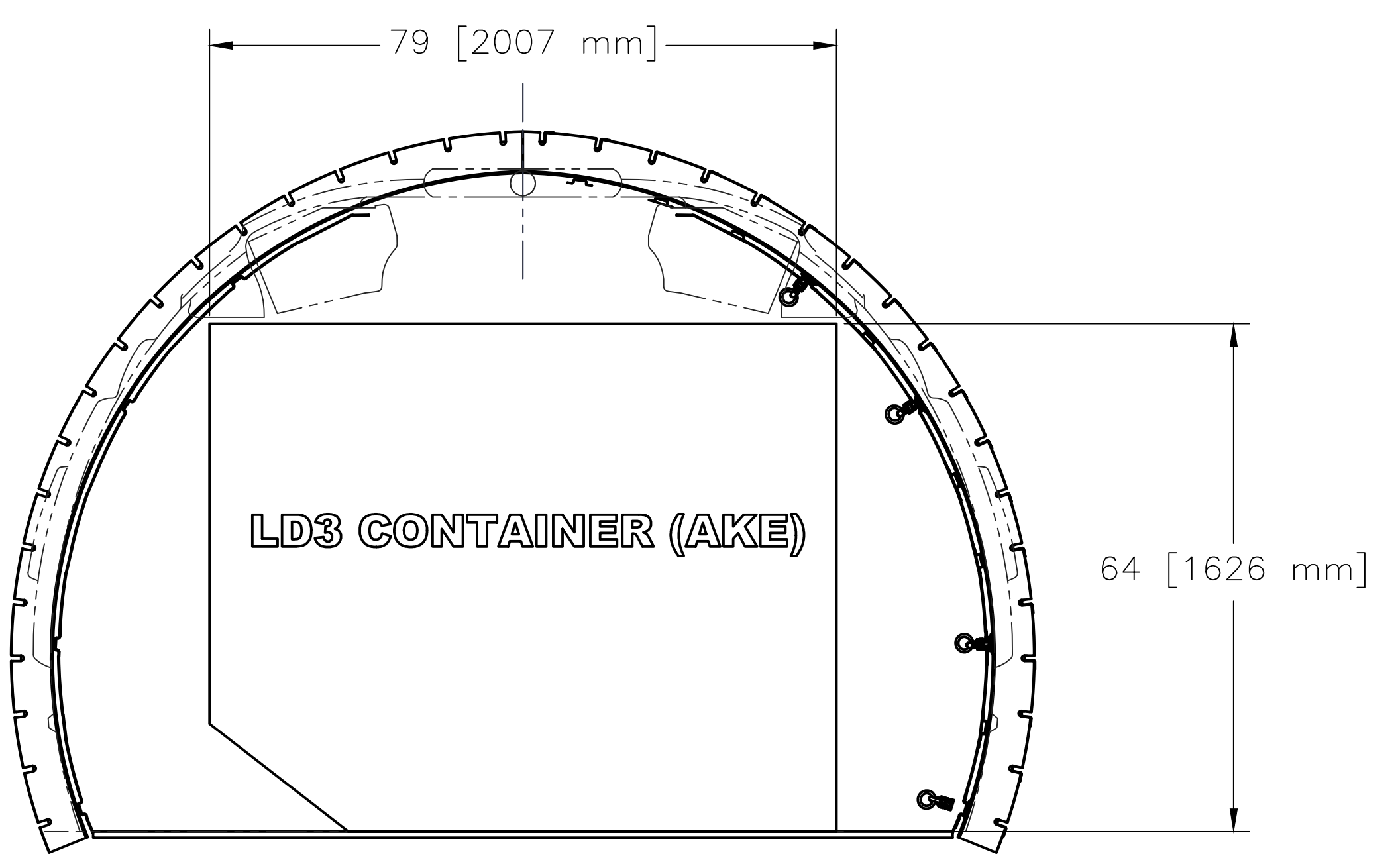

VIEW A-A
FUSELAGE CROSS SECTION

DWG NO 101-8030 SH 12

QTY REQD	PART OR IDENTIFYING NO.	MANUFACTURE OR DESCRIPTION	MATERIAL SPECIFICATION	ZONE	ITEM
PARTS LIST					
UNLESS OTHERWISE SPECIFIED					
FABRICATION		1. BREAK ALL SHARP EDGES 0.01" MAX.			
T.L. 1" - 78"		2. METRIC UNITS IN BRACKETS FOR REFERENCE ONLY			
S.D. 1/64" 1" - 78"		INTERPRET DIM AND TOL PER ASME Y14.5M-1994			
: F57HCB501 - 78"					
DRAWN		J. GENOVA		9-14-10	
CHECKED					
CHECKED (STRESS)					
APPROVED					
TITLE		CONTAINER PACKING STUDY (PRELIMINARY)			
SIZE		E		DWG NO 101-8030	
SCALE		NPS		REV NCL	
				SHEET 2 OF 2	

