

## Door Opening @94" Wide

Study to determine maximum possible length/width/height odd-sized cargo insertion into EMB-145 fuselage through LUD

Designation	Crate size				Insertion parameters				
	L	W	H	Pass	d0	d18	d20	d19	d13
Crate1	144	60	50	N	--	--	--		
Crate2	144	40	50	✓	60	155.5	13		
Crate3	168	40	60	N	60	157	11		
Crate4	216	40	40	N	55	158	10		
Crate5	240	30	30	N	55	158	10		
Crate6	300	16	30	✓	55	161	9		

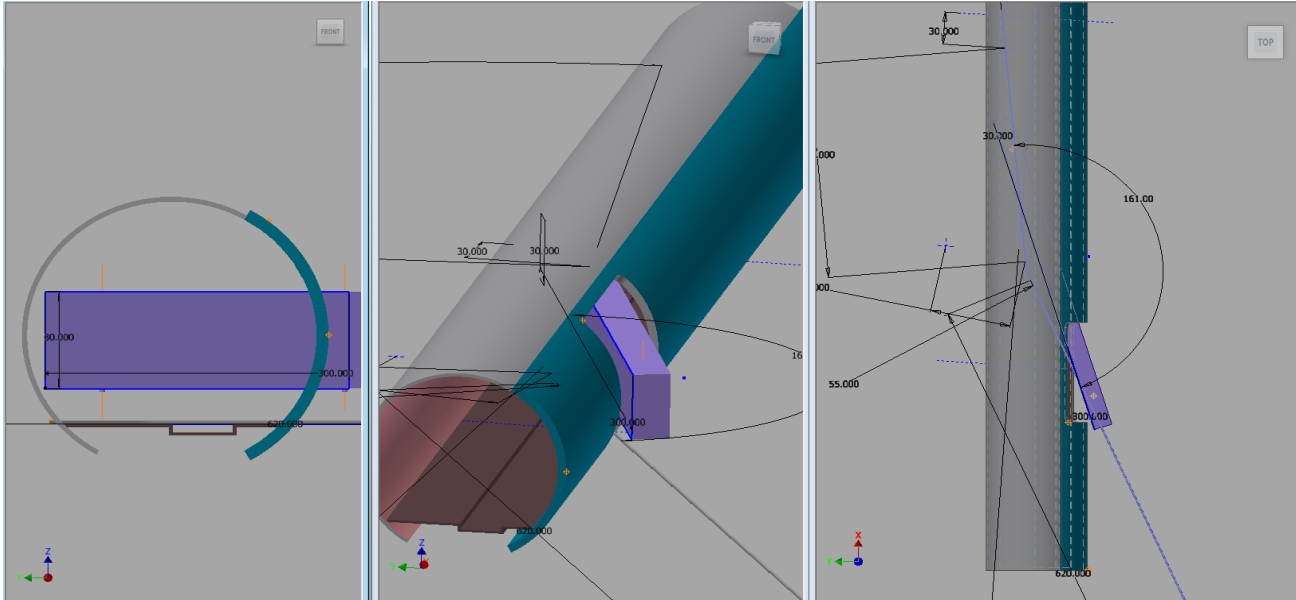

### Standard Cargo Containers

Designation	L	W	H	Pass
LD1	92	60.4	64	N
LD2	61.5	60.4	64	N
LD3	79	60.4	64	N
LD6	160	60.4	64	N
LD9	125	88	64	N

